

NRF-Shield Kit

1 DESCRIPTION

The PTSolns *NRF-Shield* is a shield intended to be used with the common nRF24L01+. This shield can work with any of the three common nRF packages: the standard size, the mini and the +PA+LNA. All three of are referred collectively to as “nRF”. The onboard NRF interface can be powered by the 3.3V pin of the below microcontroller or by the Vin pin. An onboard 3.3V voltage regulator and capacitors condition the voltage for the NRF interface if using the external Vin powering option.

Hardware pin configurations give the user flexibility in implementing their design, allowing users to choose between different hardwired pin assignments. The shield offers I2C and SPI interfaces as well as a small prototyping section, as well as additional pull-up resistors in case they are needed.

The shield’s formfactor has the same width as the Uno R3 or Leonardo, etc., but is shorter in length. Three of the four mounting holes on the Uno R3/Leonardo, etc. are found on the *NRF-Shield*, with the same position and diameter. The fourth mounting hole was sacrificed to add an SPI interface. Although the shield is fully stackable, for best RF communication, this shield should be installed as the topmost layer in the stack. The *NRF-Shield* is compatible with the Uno R3, Leonardo, Mega R3, Due, and any other similar microcontrollers.

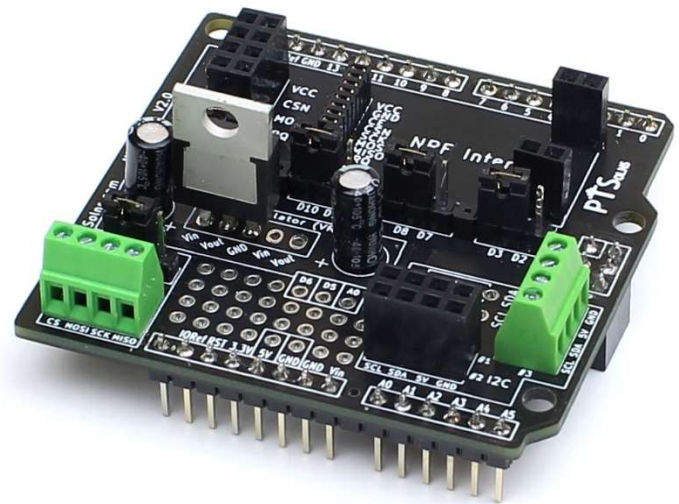

Table of Contents

1	DESCRIPTION	1
2	DOCUMENT REVISION HISTORY	3
3	PRODUCT FEATURES	4
3.1	NRF INTERFACE	4
3.2	CONFIGURABLE WIRED PIN ASSIGNMENTS	5
3.3	POWER.....	8
3.4	I2C INTERFACE.....	9
3.5	SPI INTERFACE	10
3.6	PROTOTYPING SECTION.....	11
3.7	COMPATIBILITY & STACKABILITY	11
3.8	SILKSCREEN PRINTING.....	12
3.9	MARK OF AUTHENTICITY.....	12
4	PHYSICAL PROPERTIES	13
5	TROUBLESHOOTING	14
6	REFERENCES.....	15

2 DOCUMENT REVISION HISTORY

Current document revision is Rev 0.

3 PRODUCT FEATURES

This section highlights notable features of the *NRF-Shield*.

3.1 NRF Interface

The *NRF-Shield* is designed to work with the common nRF24L01+ packages: mini, standard and +PA+LNA. These three common packages are shown in Figure 1. Footprints for all three are built into the design, collectively called the “NRF Interface”, and is shown in Figure 2.

NOTE: Although physically possible, the user should not insert more than one nRF24L01+ module into the NRF Interface at once.

NOTE: Although it is physically possible to solder the headers to insert the nRF24L01+ modules onto the back side of the *NRF-Shield*, the user should take caution as doing so will cause the pinouts of the headers to be mirrored. Do not insert the nRF24L01+ module onto the back of the *NRF-Shield*.

NOTE: The large package of the nRF24L01+, namely the nRF24L01+PA+LNA should be mechanically supported with two extra pins near the antenna. These pins are grounded. The user is encouraged to solder one 1x1 Pin male header on either side of the antenna and a 1x2 Pin female header onto the *NRF-Shield*.



Figure 1: nRF24L01+ packages: mini, standard, +PA+LNA.

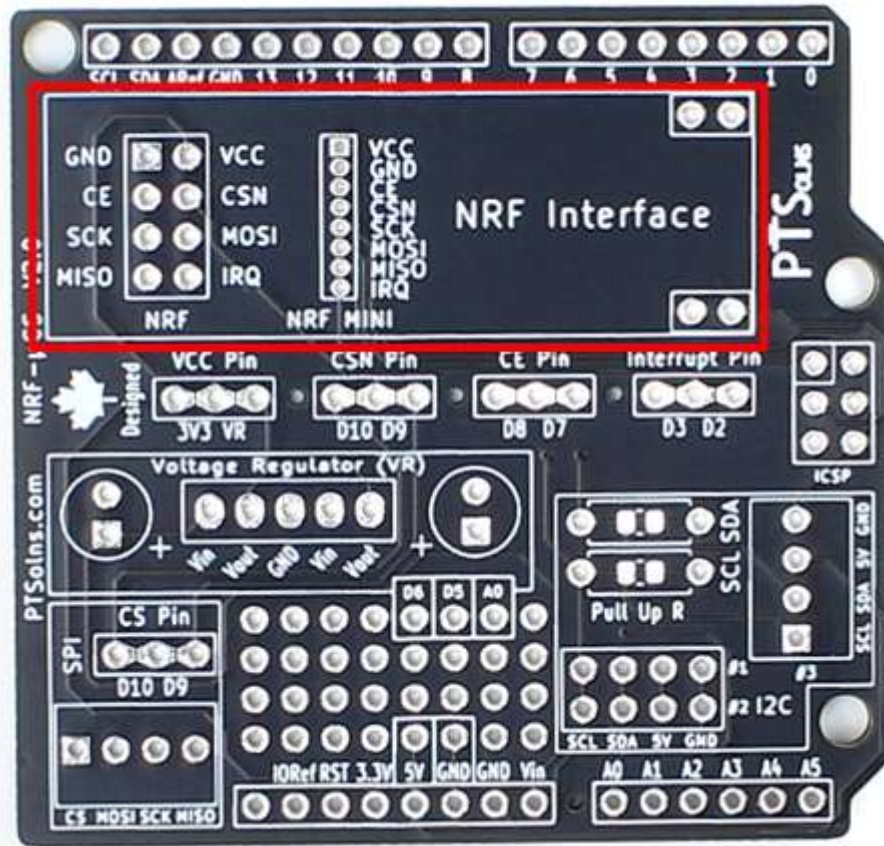

Figure 2: The NRF Interface designed for all three common packages of the nRF24L01+ module.

3.2 Configurable Wired Pin Assignments

The *NRF-Shield* is designed to be compatible with other shields, such as the *Proto-Shield*, in which several pin may have already been assigned and are not available to use on multiple shields. For example, a lower stacked shield may use the digital pin D2 as an interrupt with a sensor module. This means that D2 is not available to be used in the *NRF-Shield*. To overcome such conflicts, the wired pin assignments on the *NRF-Shield* can be configured. This can be seen in Figure 3. The configuration options are as shown in Table 1.

There are two common methods to realize the configurations of the pin assignments. A semi-permanent method is to simply solder across the respective teardrop-shaped jumper pads, as shown in Figure 4. A tutorial video on how to best solder such connections can be found here: <https://youtu.be/AOkdQ0txKpA?si=tAhV1ZBxzoEL5NSU>

Alternatively, a temporary method to set the configuration is to solder male header pins to the various through-hole pins and use 2-pin jumper caps. The row of pins relating to the configuration options of the NRF Interface has three non-plated through holes so that the user does not have to use four 3-Pin male header section, but rather a single 15-Pin male header to make soldering easier. Solder a 15-Pin male header into place, but do not solder the three non-plated through holes. Afterwards, with a pair of pliers pull out the pins in the non-plated through holes.

The final product with the pin removed is shown in Figure 5. Note that a similar non-plated through hole exists for one of the stacking row headers.

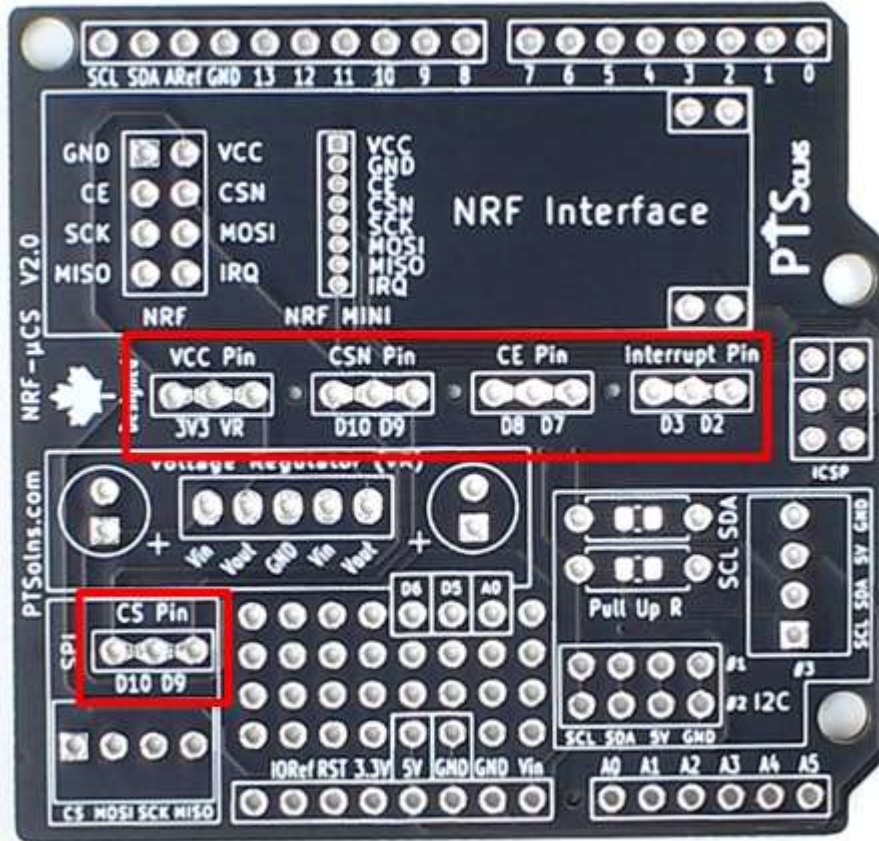

Figure 3: Configurable wired pin assignments.

Table 1: Configurable wired pin assignments.

Interface	Pin on module	Available configuration
NRF Interface	IRQ	D2, D3
	CE	D7, D8
	CSN	D9, D10
SPI	CS	D9, D10

NOTE: The following signals are hardwired. For SPI: MISO, MOSI, SCK. For I2C: SDA, SCL.

NOTE: CSN of the NRF Interface and CS of the SPI interface share the same available configuration.

NOTE: There is an additional configurable wired pin assignment relating to powering the NRF Interface. This is discussed in Section 3.3.

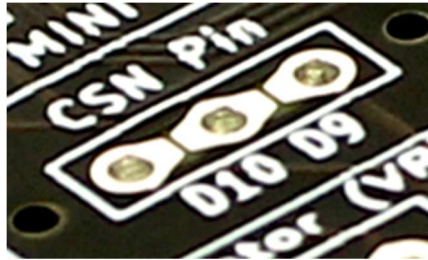

Figure 4: Teardrop jumper pad.

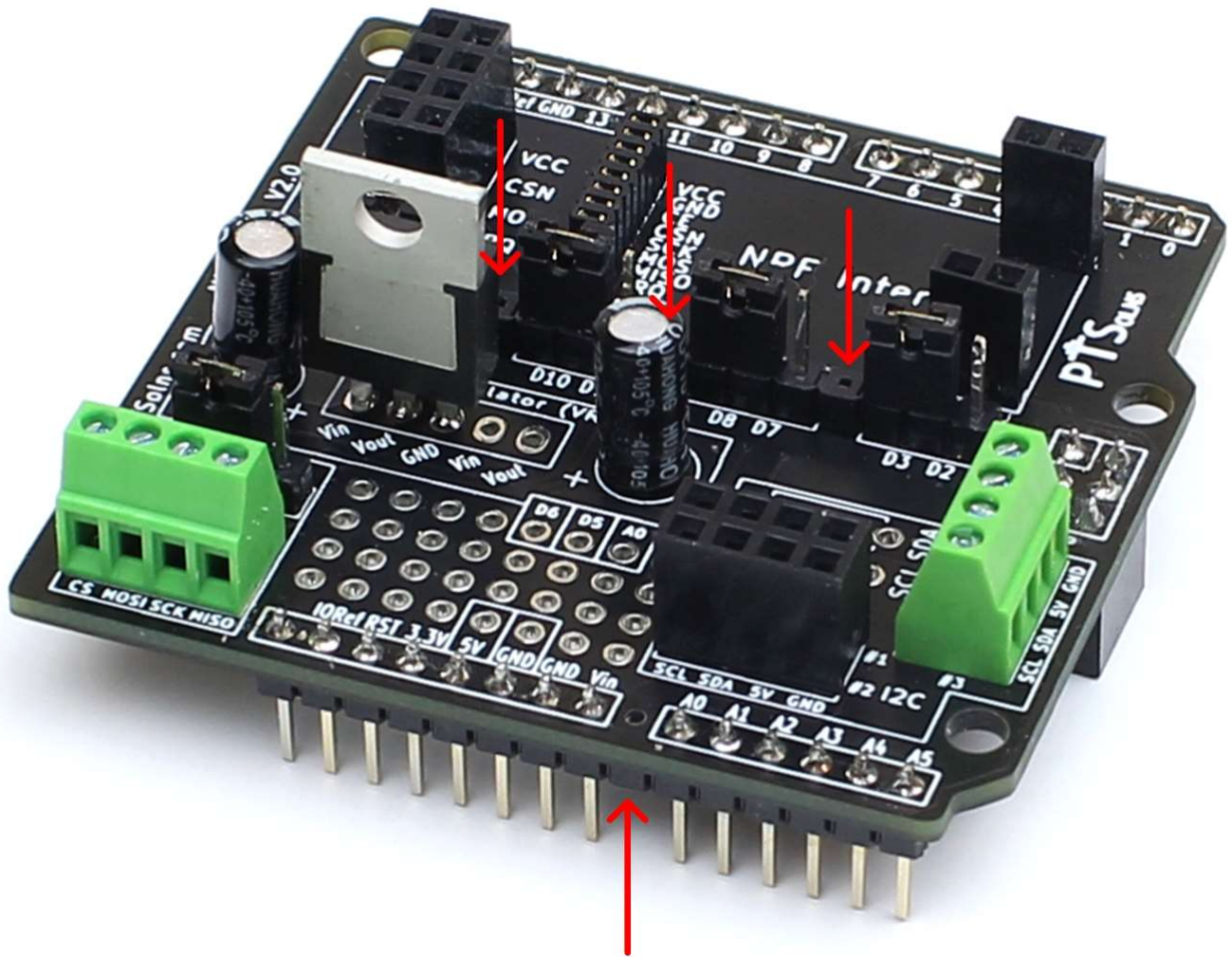

Figure 5: Non-plated through holes on the NRF-Shield.

3.3 Power

The NRF Interface can be powered in one of two methods (in the “VCC Pin” box), as follows:

- 1) Via the 3.3V Pin of the microcontroller below.
- 2) Via the external Vin Pin.

The user can make the selection of which method to select by setting the appropriate jumper as seen in Figure 6 in the upper red box with the label “VCC Pin”. How to make and change the jumper is explained in Section 3.2. If the first method is used, then the entire section within the “Voltage Regulator (VR)” is ignored and the supply voltage comes from the 3.3V Pin of the microcontroller below.

NOTE: The right-most capacitor footprint as seen in Figure 6 is strongly recommended to be populated with at least a 10uF capacitor, regardless of which power option is used.

If the second method is used, then the section within the “Voltage Regulator (VR)” is active. In this case the external “Vin” pin supplies power to the voltage regulator “Vin” pin. The user must solder a 3.3V voltage regulator in place of the footprint. Both input and output capacitor footprints are recommended to be populated.

NOTE: The voltage regulator footprint has five through holes, as seen in Figure 6. This is to allow any combination of pinout arrangements of various voltage regulators.

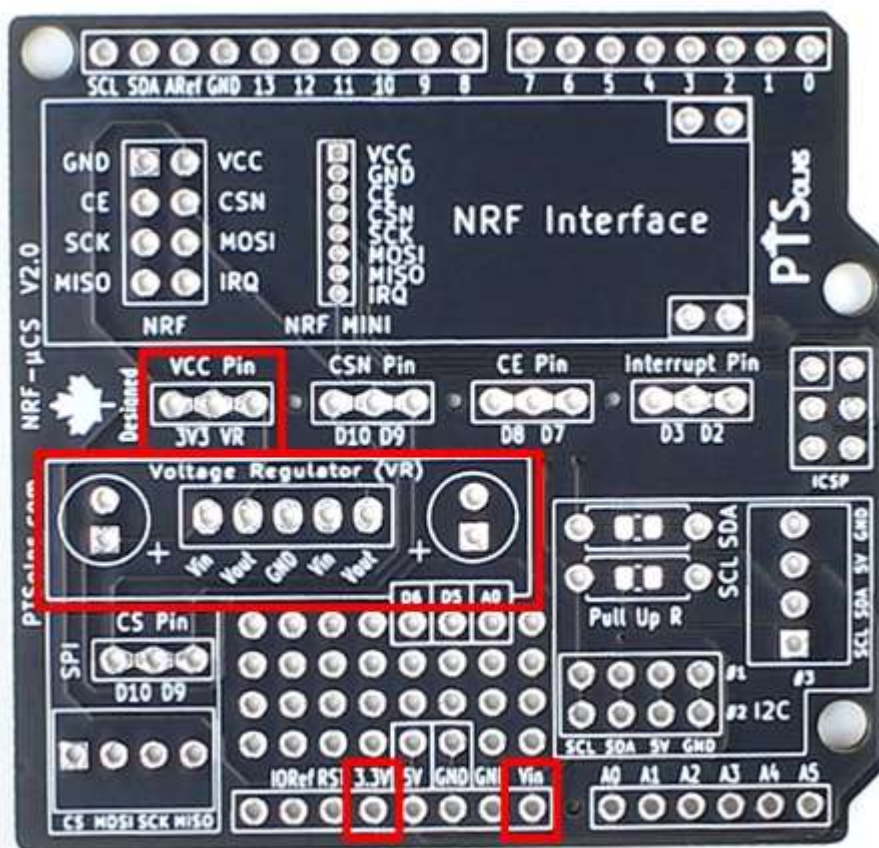

Figure 6: Powering options for the NRF Interface.

3.4 I2C Interface

Onboard the *NRF-Shield* are three I2C interfaces, marked as “#1”, “#2”, and “#3” in Figure 7. The first two interfaces (#1 and #2) are intended to be used with a 2x4 Pin 2.54mm/0.1in female header. But the footprint will also fit a similar male header. The third interface is intended to be used with a 4-Pin 2.54mm/0.1in screw terminal.

There are pull-up resistor footprints available for both the SDA and the SCL lines. The footprints can accommodate THT as well as 0805 SMD, which is available on both sides of the board.

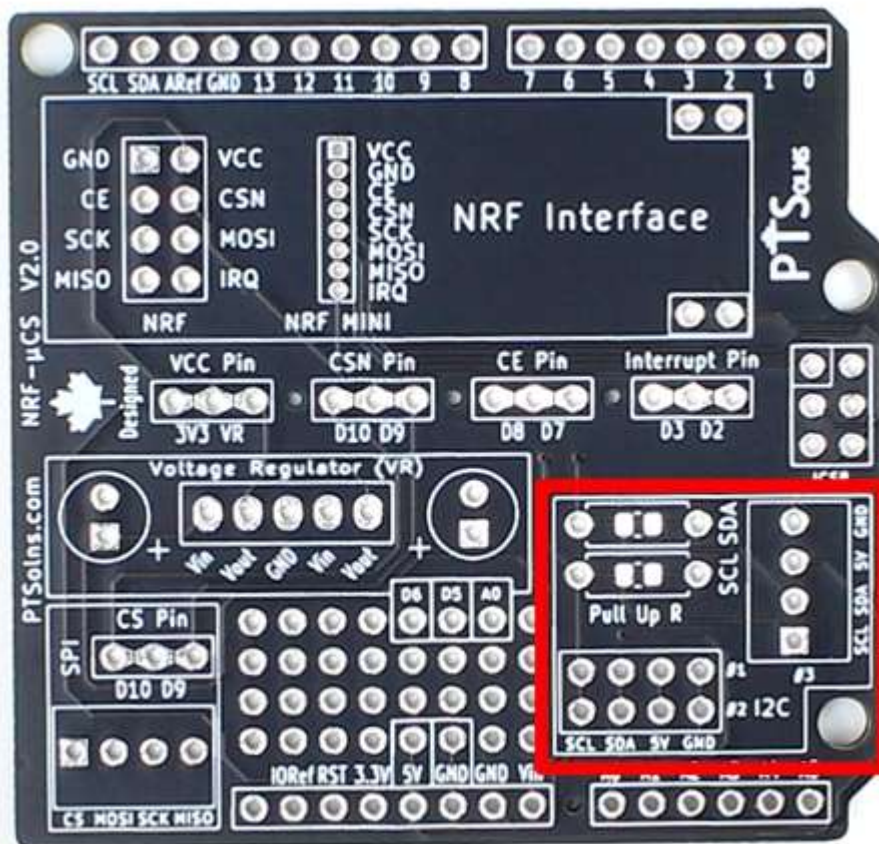

Figure 7: I2C interface on the NRF-Shield.

3.5 SPI Interface

Onboard the *NRF-Shield* is an SPI interface, as shown in Figure 8. This interface is intended to be used with a 4-Pin 2.54mm/0.1in screw terminal. The CS Pin can be configured to be either digital pin D9 or D10, as discussed in Section 3.2. Note however that the other three remaining SPI pins (MOSI, SCK, MISO) are hardwired.

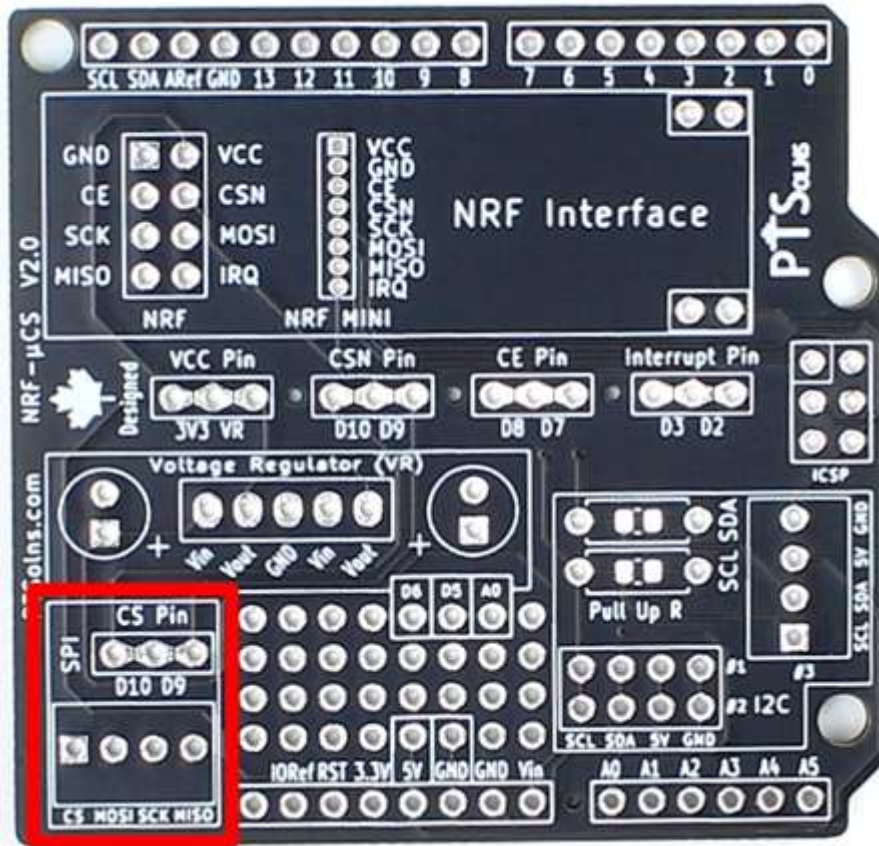

Figure 8: SPI interface on the NRF-Shield.

3.6 Prototyping Section

A small prototyping section exists on the *NRF-Shield* as shown in Figure 9. The five pins on the edge of the prototyping sections, marked accordingly, are hardwired as follows: digital pins D4 and D5, analog pin A0, 5V and ground. This allows the user to add one or two small components and interface/control with the digital or analog pins of the below microcontroller.

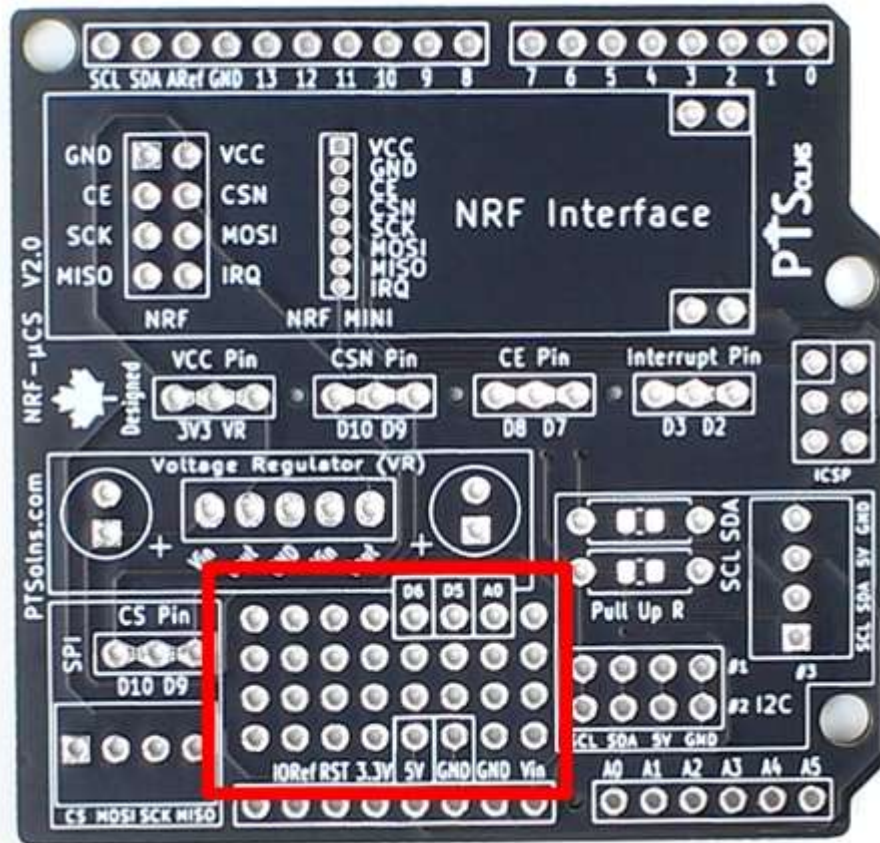

Figure 9: Prototyping section onboard the NRF-Shield.

3.7 Compatibility & Stackability

The physical PCB outline has the same width as compared to the Uno R3 or Leonardo, etc., but is shorter in length. Three of the four mounting holes on the Uno R3/Leonardo, etc. are found on the *NRF-Shield*, with the same position and diameter. The fourth mounting hole was sacrificed to add an interface (see Section 3.5). The *NRF-Shield* is compatible with the Uno R3, Leonardo, Mega R3, Due, and any other similar microcontroller.

Although the shield is fully stackable, for best RF communication, it should be installed as the topmost layer in a stack.

3.8 Silkscreen Printing

The *NRF-Shield* has silkscreen printing on both sides of the board. This is done for convenience of the user during assembly and configuration.

NOTE: It is not recommended to mount a nRF24L01+ module onto the backside of the *NRF-Shield* as the pinout of the connecting header will be mirrored will not align properly.

3.9 Mark of Authenticity

Authentic PTSolns PCBs have a black solder mask color and are marked with the “PTSolns” logo in white silkscreen printing. The “Canadian Designed” symbol, consisting of the Canadian Maple Leaf with the word “Designed” underneath, can also be found on the PCB in white silkscreen printing. The “PTSolns” trademark and the “Canadian Designed” symbols are shown in Figure 10.

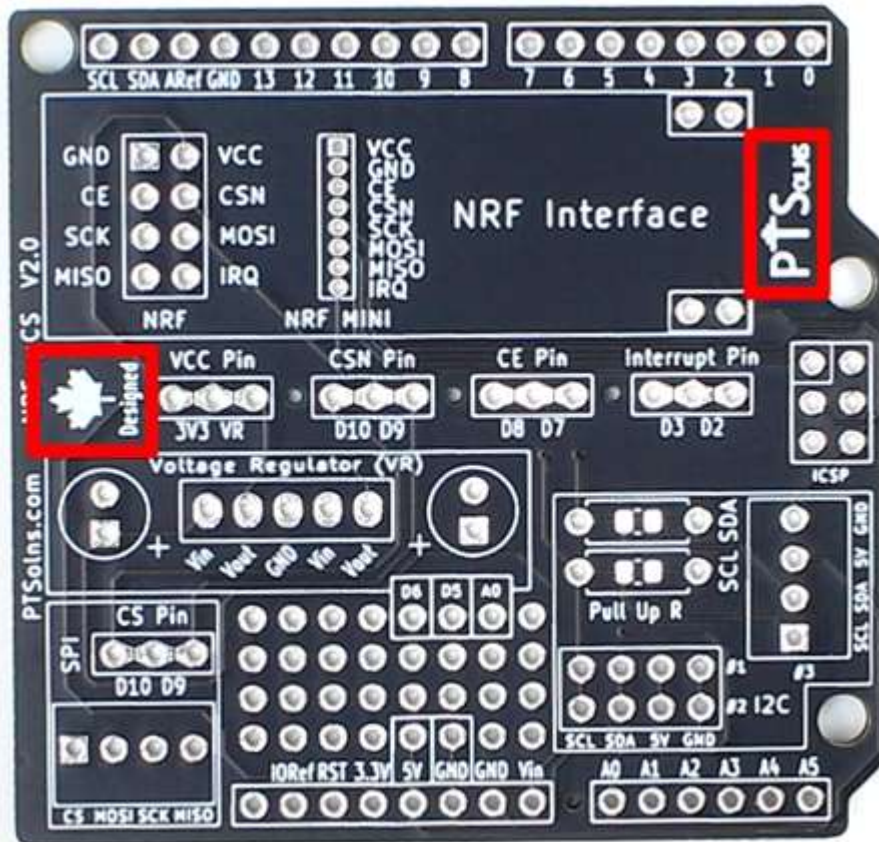

Figure 10: The “PTSolns” trademark and the “Canadian Designed” symbol found on authentic PTSolns PCBs.

4 PHYSICAL PROPERTIES

The physical properties of the *NRF-Shield* are outlined in Table 2.

Table 2: Physical Properties.

	Quantity	Value	Reference
PCB	Length	55.88 mm	Figure 11
	Width	53.34 mm	Figure 11
	Thickness	1.6 mm	--
	Weight (all components, not including nRF24L01+ module)	19 g	--
	Color	Black	--
	Silkscreen	White	--
Material	Lead free HASL-RoHS surface finish		--
	FR-4 base		--
Mounting Holes	3x each with 3.2 mm diameter		--

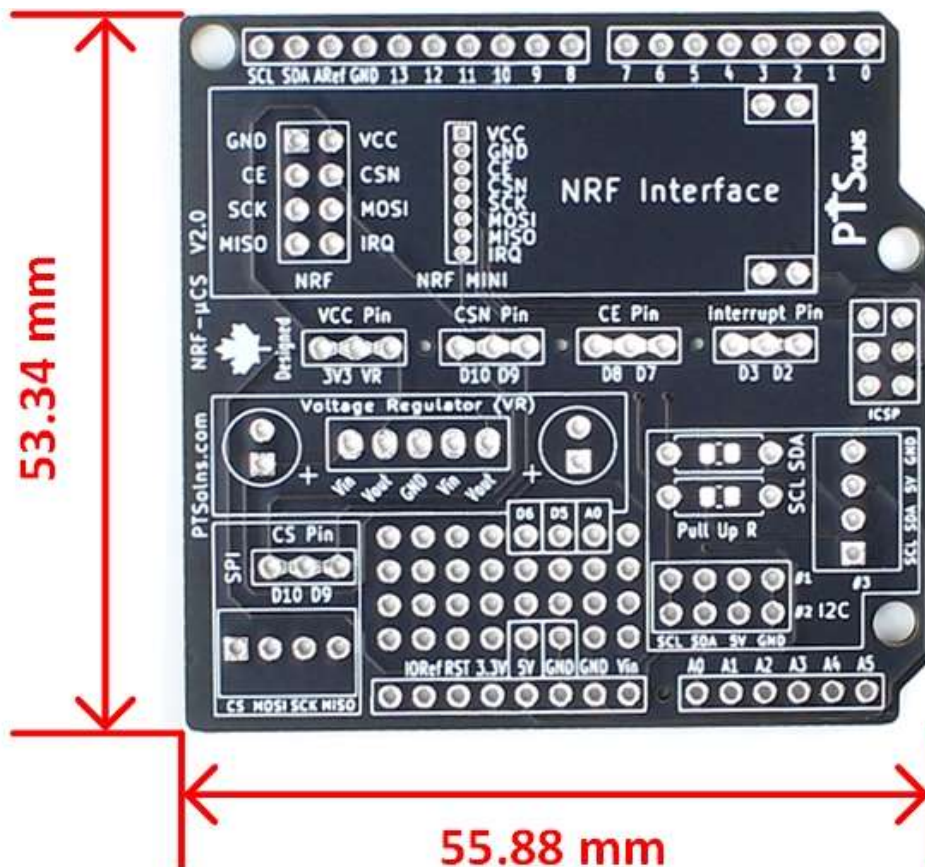

Figure 11: Dimensions of the NRF-Shield.

5 TROUBLESHOOTING

If after assembly the *NRF-Shield* does not function as expected, please view the following troubleshooting help:

- 1) Issue: No communication with nRF24L01+ module.
Solution: The 2x3 Pin female header was not installed (upside-down). This header is essential in carrying the SPI signals required to communicate with the nRF24L01+ module.

- 2) Issue: No power on NRF Interface.
Solution: Voltage regulator is not soldered into the correct through-holes. Check pinout assignment of the voltage regulator and ensure the proper three pins are used.

- 3) Issue: I2C keeps corrupting/not working.
Solution: Check if pull-up resistors are required, and if so, install them on the *NRF-Shield*. Ensure all I2C protocol rules are followed.

- 4) Issue: nRF24L01+ communication intermitted/not stable.
Solution: Ensure that at least a 10uF capacitor is installed on the input to the *NRF-Shield*. See Section 3.3 for details. If using the nRF24L01+PA+LNA at max power setting (software) with many frequent transmissions, along with the 3.3V powering option, it might be that the below microcontroller cannot supply enough/stable power. In this case, switch the power over to method 2 as outlined in Section 3.3.

“RF is hard.” – D. Cornish

If all else fails, contact our support team:

<https://ptsolns.com/pages/contact>

6 REFERENCES

This section lists relevant references.

- Instructional *NRF-Shield* video:
https://youtu.be/4Tcls_I2Wf0?si=9S-qrA09jLT2w-XA
- How to solder jumper pads video:
<https://youtu.be/AOkdQ0txKpA?si=tAhV1ZBxzoEL5NSU>
- PTSolns Documentation Repository Sub-Domain:
<https://docs.PTSolns.com>
- PTSolns website:
<https://PTSolns.com/>
- PTSolns support:
<https://ptsolns.com/pages/contact>

The *NRF-Shield* is recommended to be used in conjunction with the PTSolns *Uno R3+*.

- *Uno R3+* datasheet:
https://docs.ptsolns.com/Products/PTS-00194_Uno_R3_Plus/Datasheets/Datasheet_PTS-00194_Uno_R3_plus.pdf

Other PTSolns shields.

- *Proto-Shield* datasheet:
https://docs.ptsolns.com/datasheets/Datasheet_PTS-00153_Proto-Shield.pdf
- *Interface-Shield* datasheet:
https://docs.ptsolns.com/datasheets/Datasheet_PTS-00156_Interface-Shield_Kit.pdf